

Model Number:

Type:

Job:

Approvals:

## FEATURES

- Comes standard with G2 Self-Test/Self-Diagnostics.
- Following AC power failure, cover doors open instantly and provide emergency lighting to area required, with automatic retraction when AC power is restored.
- Cover doors may be color matched, textured, or even wall-papered to match any interior finish. When closed in normal mode, the unit is almost invisible.
- Recessed Wall or Ceiling mount.
- Doors are operated automatically using a spring and solenoid with magnetic latch for years of worry-free operation.
- Flush fitting covers feature internal reflective surfaces to maximize light output.
- No unauthorized access to lamp heads prevents tampering.

## LIGHTING

- Dual MR16 Quartz Halogen lamps available in 20, 35, 50, or 75 watts.
- Lamps have a life of up to 5,000 hours, most installations will never require replacement.
- Swivel mounted lamps are fully adjustable and lock into the desired position.

## ELECTRONICS

- Universal AC input 120/277 VAC.
- Low power consumption in standby mode.
- Isolated switch mode power supply with regulated current and voltage output to lamp load and battery.
- Automatic, controlled charge rate for fast charged and maximum battery life.

## AUTOMATIC BATTERY DIAGNOSTICS

- Advanced microprocessor continuously monitors all charger functions and battery condition.
- Automatically performs all tests and visual indications as required by UL 924.
- Multicolor LED diagnostic display.
- Optional full-function alpha-numeric display (remote test panel).

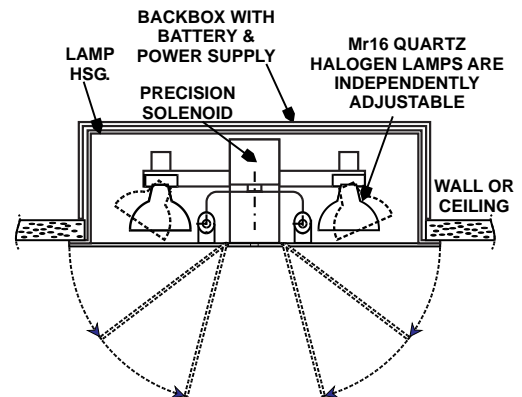
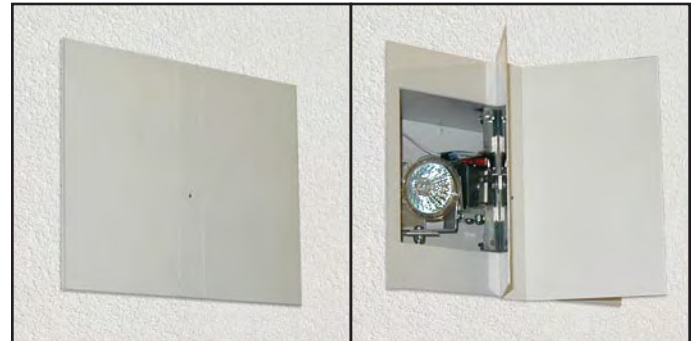

NORMAL MODE- CLOSED

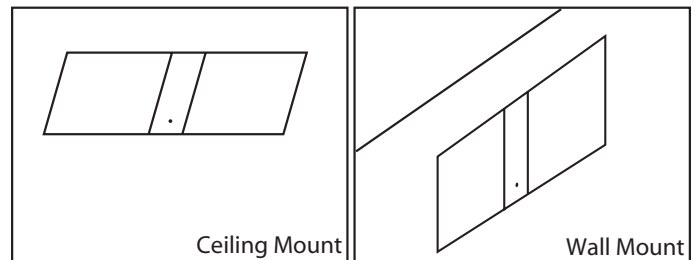

## CONFORMANCE TO CODES & STANDARDS

Exitronix products are electrically safe and meet or exceed the following: UL 924, N.E.C., OSHA, and N.F.P.A. Life Safety Code 101.

## WARRANTY

Any component that fails due to manufacturer's defect is guaranteed for 5 years, with a 5 year prorated warranty on the battery. Warranty does not apply to damages caused by improper installation, abuse, fire or acts of God.

SPECIFICATIONS ARE SUBJECT  
TO CHANGE WITHOUT NOTICE



## SUGGESTED SPECIFICATION

Install EXITRONIX Stealth Series recessed emergency light fixture manufactured by Exitronix. In normal mode, dual lamp heads, charger and battery shall be fully recessed and covered by hinged doors with reflective internal surfaces and no exposed mounting screws. Upon loss of utility power, doors will open immediately, lamps will be energized and light will be reflected on to the path of egress. Upon restoration of utility power, lamps will extinguish and the reflective doors will automatically retract. The door linkage shall allow manual movement without breakage or misalignment. Door and lamp position shall be adjustable to allow placement of light beams to any desired position. Lamps shall be 12 VDC MR16 Quartz Halogens with total power rating up to 150 watts. The battery charger shall be an isolated power supply with universal 120/277 VAC input via two-wire feed. Automatic battery diagnostics shall be included with all models and shall perform all test functions and fault displays required by UL Standard 924.

## BATTERY RUN TIME

| Lamp Watts | Run Time Hours | Battery Type | Backbox Height "H" |
|------------|----------------|--------------|--------------------|
| 20         | 1.5 - 4        | LC           | 15 1/2"            |
| 20         | 1.5 - 4        | NC           | 15 1/2"            |
| 35         | 1.5 - 2        | LC           | 15 1/2"            |
| 35         | 4              | LC           | 23"                |
| 35         | 1.5 - 4        | NM           | 15 1/2"            |
| 35         | 1.5 - 2        | NC           | 15 1/2"            |
| 50         | 1.5 - 2        | LC           | 15 1/2"            |
| 50         | 2 - 4          | LC           | 23"                |
| 50         | 1.5            | NC           | 15 1/2"            |
| 50         | 2              | NM           | 15 1/2"            |
| 75         | 1.5            | LC           | 15 1/2"            |
| 75         | 2              | LC           | 23"                |
| 75         | 1.5            | NM           | 15 1/2"            |

## MOUNTING DATA AND DIMENSIONS

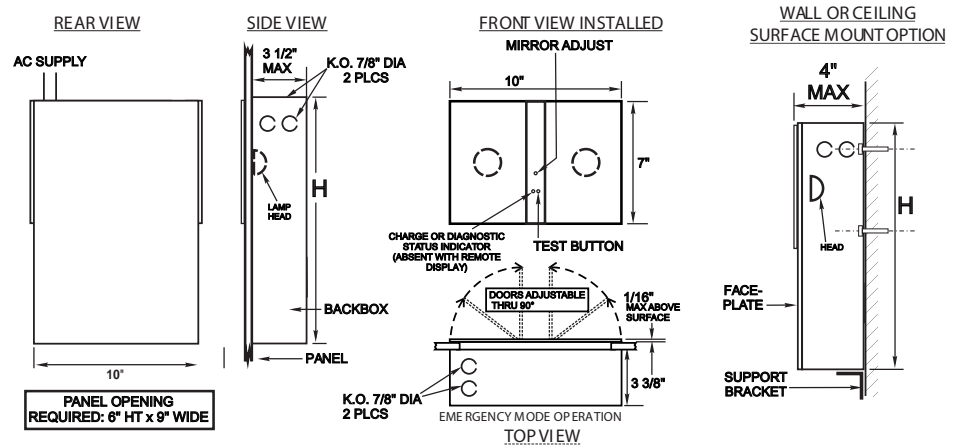

## DIAGNOSTIC FUNCTIONS

| Continuous Monitoring | Every 28 Days            | Every 12 Months   |
|-----------------------|--------------------------|---|
| Lamp Connections      | Transfer Switch Function | Full emergency operation test with test/fail and manual report signal |
| Battery Connections   | Reduced Battery Capacity |   |

## ORDERING INFORMATION

| MODEL       | LAMP WATTAGE         | BATTERY TYPE   | BATTERY RUN TIME  | OPTIONS  |
|-------------|----------------------|--|---|--|
| S = Stealth | 20<br>35<br>50<br>75 | WB = Sealed Lead Calcium<br>NC = Nickel Cadmium<br>NM = Nickel Metal Hydride | BLANK = 90 MIN<br>2 = 2 Hour<br>4 = 4 Hour<br>(SEE TABLE ABOVE) | RTP = Remote Test Panel<br>DR = Suitable for Damp Location<br>SM = Surface Mount<br>CF (X) = Custom Finish (X = Color Selection) |

**EXAMPLE: S20-WB-2-RTP-DR**

| YOUR LOCAL REPRESENTATIVE IS: |
|-------------------------------|
|                               |

**EXITRONIX**<sup>TM</sup>  
A DIVISION OF THE  
**BARRON LIGHTING GROUP**  
1911 W. Parkside Lane • Phoenix, AZ 85027  
(800) 533-3948 • Fax: (623) 580-8948  
www.exitronix.com • www.barronltg.com