

Model Number:

Type:

Job:

Approvals:

PRODUCT FEATURES

- Contemporary, low-profile, streamlined design
- Suitable for Damp or Wet Locations (0° to 50° C)
- Optional Cold Weather package (-20° to 50° C)
- 2 x 6V 6W Xenon lamps for emergency mode.
- Durable die-cast aluminum housing
- Optional remote unit available
- Comes standard with G2 Self-Test/Self-Diagnostics
- UV stable polycarbonate lens and mirrored reflector
- UL94-5VA flame rating on polycarbonate components
- Test switch and charge rate indicator.
- Wall or ceiling mounted
- 120/277V dual primary 60Hz input
- Nickel cadmium battery delivers more than the required 90 minutes capacity to emergency lamps
- Quick connect mounting back plate
- Optional LED lamps with sensor provide decorative lighting at night when unit is not in emergency mode
- Low voltage disconnect
- 5 year warranty
- ETL Listed



The Exitronix Triton series is ideal for applications where low-profile, architectural emergency egress lighting is required. Contemporary design and durable die-cast aluminum construction provide attractive, reliable egress lighting that blends seamlessly into any exterior design. Perfect for damp, wet, or cold environments.

DIMENSIONS

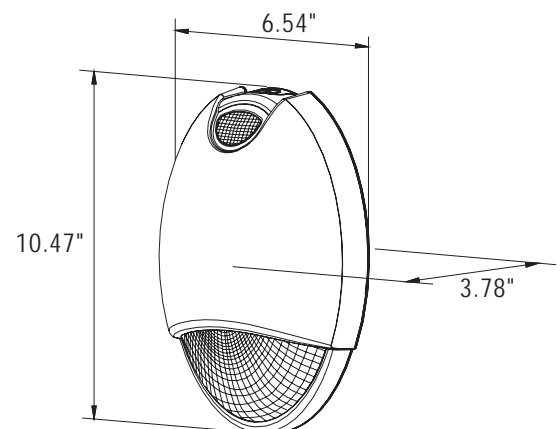

WARRANTY

Any component that fails due to manufacturer's defect is guaranteed for 5 years with a separate 5 year pro-rated warranty on the battery. The warranty does not cover physical damage, abuse or acts of God and Exitronix reserves the right to charge for such repairs if deemed necessary

SPECIFICATIONS ARE SUBJECT
TO CHANGE WITHOUT NOTICE



CONSTRUCTION

Decorative, low-profile, architectural design with die-cast aluminum housing with durable powder coat finishes in white, black and dark bronze. Housing can be paint matched in the field to match any exterior surface. The Triton Series features a fully sealed and gasketed enclosure for Damp and Wet Location applications. Two rigid conduit entry points and a universal J-box mounting pattern make installation quick and easy.

ILLUMINATION

Units come standard with two 6 volt, 6 watt Xenon lamps. Features a mirror-bright reflector and prismatic polycarbonate refractor for ideal light output. Optional LED's with sensor provide decorative illumination at night when unit is not in emergency operation.

ELECTRONICS

Dual voltage, 120 volt or 277 volt input. Circuit provides automatic brownout, short circuit, and overload protection. A momentary test switch and LED charge indicator are included.

BATTERY

Maintenance-free, Nickel Cadmium battery provides an estimated service life of 10 years with an operating temperature range of 0° to 50° C (-20° to 50° C with optional Cold Weather Package).

CODE COMPLIANCE

The Triton Series meets or exceeds all performance standards as required by UL 924, NFPA 70, NFPA 101, NEC 700.16 and OSHA.

ORDERING INFORMATION

Series	Style	Color	Options
TR - Triton	WB - NiCad Battery RM - Remote Unit Only* <small>*Does not include battery or charging circuit, requires separate 6 volt power supply, Not available with any other options.</small>	WH - White BL - Black BR - Dark Bronze	CL - Cold Location Package SRG - Green LED & Sensor SRB - Blue LED & Sensor SRA - Amber LED & Sensor SRW - White LED & Sensor

G2 SELF-TEST/SELF-DIAGNOSTICS

The circuit continuously monitors the operating condition of the AC power, battery supply voltage, emergency lamp continuity, and charging circuit. If failure occurs, visual status will occur immediately via the dual-colored LED. LED indicator will illuminate until fault has been corrected. The G2 also monitors the transfer circuit as well as performing automatic code compliant testing. The self-test will operate the equipment in emergency mode one minute every 28 days. A 30 minute full-function test is performed every six months, and a 90 minute full-function test is performed every 12 months. These tests can also be initiated manually by use of the test button.

REMOTE UNITS

The Triton Series is also available for use as a remote unit, supplied without the battery or charging circuit. The Triton remote can be run off any standard emergency lighting unit supplying 6 volts and at least 12 watts of remote power.

Note: Triton emergency lights are not equipped to run remote units.

LED ACCENT LIGHT & SENSOR OPTION

This option transforms the TRITON Emergency Unit into a multi-purpose accent light and/or night security light. LED's are available in White, Blue, Green and Amber and come standard with an internally mounted photo-cell. The accent light will be displayed through both the top and bottom lenses of the fixture. Upon power loss, the accent light automatically turns off allowing for path of egress illumination via the Xenon lamps. .

YOUR LOCAL REPRESENTATIVE IS:

EXITRONIX™

A DIVISION OF THE
BARRON LIGHTING GROUP
1911 W. Parkside Lane • Phoenix, AZ 85027
(800) 533-3948 • Fax: (623) 580-8948
www.exitronix.com • www.barronltg.com