

LE1 - EMERGENCY LIGHT W/ REMOTE CAPACITY

EMERGENCY LIGHTS

PROJECT INFORMATION

Type :

Project :

Catalog # :

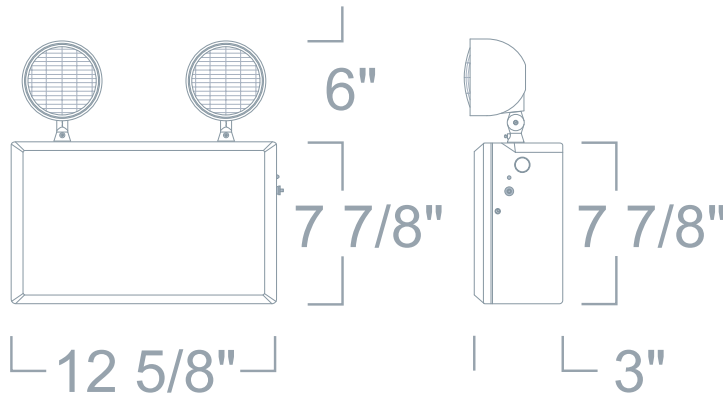

FEATURE(S):



SPECIFICATION

120V/277V input
6V/12V output

APPLICATIONS

The LE1050/LE1100 series comes in 6V and 12V units with 50W or 100W total capacity. These heavy duty emergency units are both efficient and easy to install. They have remote capabilities to power compact remote emergency lights, and are completely self-contained.

FEATURES

Low Profile design in neutral finish
Maintenance free battery with 10 years life expectancy
Universal 120V/277V operation
Equiped with two fully adjustable, glare free lights
LED Indicator light
Integral test switch

Accessories: Lamp included in packaging.

COMPATIBILITY



LE10

1-LIGHT REMOTE
EMERGENCY

Note: Electrical limitations on compatible items must be met.

ORDERING

ORDERING EXAMPLE : LE1100-6

LE1	WATTAGE	VOLTAGE
LE1	050 :50W	-12:12V
	100 :100W	-6 :6V